

SLEEVE SOLUTIONS

Simplified Sleeve Solutions for Enhanced Flexibility

Recommendations for Selecting Sleeve Width Based on Harness Diameter

tesa® Supersleeve 51036 PV6	Harness Dia. [mm]	Sleeve Width [mm]
	<12	67
	12 - 16	85
	16 - 19	100
	19 - 24	115
	24 - 29	130
	29 - 33	145
	33 - 38	160
	38 - 45	180
High abrasion resistance due to double layer design	45 - 49	195

tesa® Supersleeve 51036 PV7	Harness Dia. [mm]	Sleeve Width [mm]
	<10	50
	11 - 20	95
	21 - 30	140
	31 - 40	190
	41 - 50	230
	-	-
	-	-
	-	-
High abrasion resistance due to double layer design	-	-

tesa® Sleeve 51036 PV9	Harness Dia. [mm]	Sleeve Width [mm]
	<13	68
	13 - 16	78
	16 - 23	100
	23 - 33	130
	33 - 41	155
	41 - 54	195
-	-	
Abrasion protection, cost efficiency, and flexibility due to single layer design	-	-

tesa® Sleeve 51026 PV5	Harness Dia. [mm]	Sleeve Width [mm]
	10 - 30	45
	>30	59
	-	-
	-	-
	-	-
	-	-
	-	-
	-	-
Abrasion protection and spiral application	-	-

tesa® Supersleeve 51608 PV6	Harness Dia. [mm]	Sleeve Width [mm]
	<12	67
	12 - 16	85
	16 - 19	100
	19 - 24	115
	24 - 29	130
	29 - 33	145
	33 - 38	160
	38 - 45	180
High noise damping due to double layer design	45 - 49	195

tesa® Sleeve 68000 PV17	Harness Dia. [mm]	Sleeve Width [mm]
	<10	50
	10 - 15	68
	16 - 19	80
	20 - 25	100
	26 - 35	130
	36 - 43	160
	-	-
	-	-
Aluminum laminated glass cloth for radiant heat reflection	-	-

Recommendations for Selecting Perforation Length Based on Harness Dimension

- 10mm of space should be left between the sleeve and the start of the branch or forks
- Spot wrapping should be used on either side of the sleeve to cover the remaining exposed wire
- Sleeve perforation is available in increments of 10mm

Example:

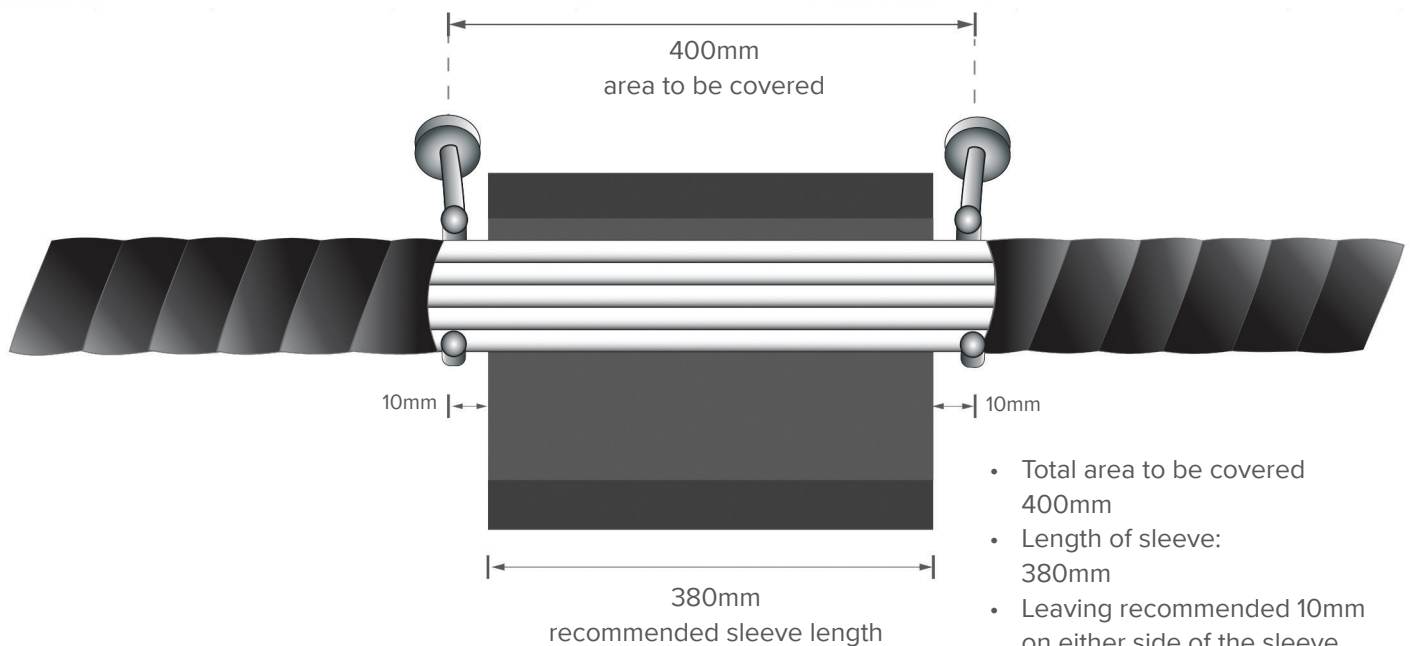

- Total area to be covered 400mm
- Length of sleeve: 380mm
- Leaving recommended 10mm on either side of the sleeve
- Perforation length standards 50-200mm every 10mm; 200-400mm every 20mm

Automotive Solution Center

tesa tape, inc.
28100 Cabot Dr. • Suite 201 • Novi, MI 48377
Phone: +1-248-699-0901 • Fax: +1-704-553-5634
Email: customer-care@tesatape.com
Web Site: www.tesatape.com

Mexico

tesa tape México S.A. de C.V.
Av. Santa Fe No. 170 • German Centre P 7-4-14
Lomas de Santa Fe • Ciudad de Mexico C.P. 01210
Phone: +52-55-5292-6978 • Fax: +52-55-2282-7580
Email: mexico@tesatape.com